



# The Wisconsin Early Mustangs

"A FEW TO PRESERVE THE BEST"

## THE FEEDBAG

From the Pres.

November 2, 1990

This month we must report on two exciting events. The first was the annual trek to Door County. This years trip was one of the best, and biggest. We had some great times, nice scenery and of course good food. High point of the trip for us gearheads was Gene Meyers getting to know a man called "Red". He showed Gene a barn full of older cars, including two restorable MUSTANGS.

After hearing Gene's story Saturday night, we were hot to trot. We called this poor guy at 7:00 A.M. Sunday and asked if we could see the cars. He told us to come over. We did, and what a thrill. He had a '65 Mustang convert., a '66 6 cyl. Mustang convert., an early '50's Packard, some '30's Mopar iron and many more. All of these are restorable machines. But, then the bubble broke. He stated that he was not interested in selling anything. He just wanted to share them with us, knowing we were enthusiasts. Well, Thanks for the hospitality Red, we sure enjoyed the viewing.

The next item was our Halloween Rally on Sunday November 28th. We had a great time on the Southeast side of Milwaukee. The event was well set up and run. The duration was just right, the scenery superb. Congratulations to Dave and Jackie Yahn, our first place winners. We feel that all who participated were also winners on this one. Thanks much to Mike Ciepluch and cohorts for a good job.

Next month we will be having the annual planning Board meeting, prior to the business meeting. Here we set the dates and events for next years activities. Regular members are welcome to sit in on this meeting which starts at 7:00 P.M.

The weather is starting to turn cold. Most of the ponys have headed to the barn. Keep warm gang, and naturally, "keep on 'stan-gin'".

Dick Doria

# FROM YOUR EDITOR



\*\*\*\*\*

*Alas, It's time once again to put our ponies back in the corral for the season and depend on our winter runners to provide transportation. The only thing I can say is that for some reason this season just seemed to fly by. Even though I did partake in many of our functions, I only logged 400 miles on my convert this year. The reason being was Sue and I, for the first time, were unable to attend any of the OTR trips, a situation we hope to amend next season.*

*In reflecting back over the past year, my biggest highlight would be the fact that I saw many new faces participate and organize many of our club functions. As president Doria stated earlier this year, Your original club officers plan to step down and give some of the new blood a chance to run the club!! I now feel comfortable that we have the proper nucleus to do this. Both Dick & I formed this organization and will be available to help the newly elected officers.*

*Finally I would like to announce Sue & I have set the date for our annual club bowling outing. Feb. 24, 1991 We would appreciate it if you would send your \$ 8 entry fee to us ASAP. The sooner we receive the entry fee, the more prizes we can purchase at discount prices.*

*Until Next Month  
Fraternally Yours  
Bob Zimmermann*

\*\*\*\*\*

## NOTICE

**YOUR ANNUAL CLUB DUES ARE DUE BY  
JANUARY 1 1991. PLEASE SEND YOUR \$15  
REMITTANCE TO CLUB HEADQUARTERS BY  
THIS DATE.**

# MINUTES FROM MEETING HELD OCT 29, 1990



- \* The meeting was called to order at 7:30 pm by president Doria.
- \* New members Bob Monninger and Dick Willms were introduced.
- \* Mary Jo read the minutes from the Sept meeting. Sharon Doria gave treasurers report.
- \* Bob Zimmermann has more club Sweatshirts for sale. If anyone is interested in getting one of these quality Russell Sweatshirts with the club logo on the front contact Bob. Cost \$20.
- \* OTR trip report of the Door County trip was given. Beautiful weather, Lots of eating as usual, special side trips to a mechanical doll museum, lighthouse, as well as cruisin the Peninsula.
- \* A report on the Club Ralley held on Oct. 28. was given. Those who attended were treated to super weather and a well put together route. A special tip of the hat to Mike Cieplauch, and Casey Chojanacki who put this event together. Winners were Dave Yahn 1st place & Dick Doria 2nd place. All participants were treated to beer, soda and snacks after the rally.
- \* Bob Z will placed a group order on Oct 19 for 10 club jackets. Bob hopes they will be ready by the November meeting.
- \* Mike Cieplauch thanked the 4 cars that turned up to help in the Sept 29 parade on KK ave
- \* Dick Doria recommended a brunch run on Dec 9 to Lyle IL. Cost would be \$19/person.
- \* Bob Z announced that the annual club bowling party will be held on Feb. 24, 1991. The fee will be \$8 a person. The top prize this year will be a VCR. He asked that you send your money in ASAP so he can start buying prizes at sale prices.
- \* The meeting was adjourned at 7:55pm.

\* \* \* \* \*



# CAR OF THE MONTH

\*\*\*\*\*



**1965 MUSTANG COUPE  
OWNER: MILLARD KABITZKE**

My bride and I bought this Vintage Burgundy Coupe in April of 1990. We are the third owners of this beauty. When we purchased the car it had only 35,000 original miles on it. A rare find indeed. It sports a 289 4V with Cruise O Matic, limited slip differential, power steering, two speed electric wipers, plus the special handling package. We also have in our possession the original window price sticker. We enjoy driving and taking trips together very much.



# W.E.M. ANNUAL GIMMICK BOWL



**DATE:** SUNDAY FEBRUARY 24, 1991  
**TIME:** 12:15 PM  
**PLACE:** OAK CREEK CLASSIC LANES

OUR ANNUAL BOWLING CLASSIC IS OFF AND RUNNING. FOR THOSE OF YOU WHO HAVE NOT PARTICIPATED IN THE PAST THIS IS A FUN OUTING, AND WINNING PRIZES DOES NOT RELATE TO YOUR BOWLING SKILL. ALL ARE WELCOME SO INVITE YOUR FRIENDS, RELATIVES, AND NEIGHBORS.

THERE WILL BE AN APPROXIMATE PRIZE GIVE A WAY VALUED AT OVER \$500. THE TOP PRIZE WILL BE A VCR. THREE RUNNER UP PRIZES VALUED AT \$30-\$50 EACH WILL BE AWARDED. FINALLY TEN OR MORE CONSOLATION PRIZES VALUED AT \$10-\$20 WILL BE GIVEN OUT.

THERE ARE ALSO MANY MORE SURPRISES AND GIVE AWAYS WHICH WILL BE DONATED BY THE BOWLING ESTABLISHMENT.

THE ODDS ARE IN YOUR FAVOR, SO PLEASE RESPOND A.S.A.P., AS THE SOONER WE HAVE THE CASH THE SOONER WE CAN BUY MORE PRIZES AT DISCOUNTED PRICES. THE COST IS ONLY \$8.00 PER BOWLER. THIS FEE IS FOR THREE GAMES OF BOWLING AND PRIZES.

ALL MONEY DUE BY JANUARY 15. (EARLIER PLEASE).

FILL OUT THE COUPON BELOW

## W.E.M BOWLING TOURNAMENT

**NAME:** \_\_\_\_\_

**PHONE:** \_\_\_\_\_

**# OF BOWLERS** \_\_\_\_\_ **@ \$8.00 =** \_\_\_\_\_

SEND TO:  
**BOB ZIMMERMANN**  
 2307 W CARRINGTON AVE  
 OAK CREEK, WI 53154

# Shop tips

Reprinted from technical and service bulletins published by Ford Motor Company, Autolite division.

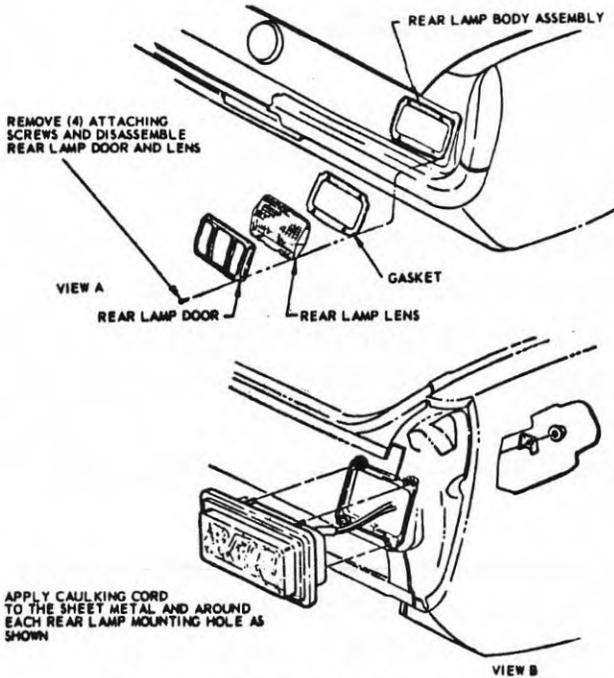

## WATER LEAK REAR TAIL LAMP (1965 Mustang - All Models)

Water may enter the tail lamp assembly on early production models and result in an inoperative tail light. This problem is caused by improper sealing of the tail lamp lens to the lamp assembly.

The problem was corrected in production on May 8, 1964 by using a new wider gasket which provides additional sealing surface to assure a better relationship between the gasket and the lens.

When encountering this condition, the tail lamp lens-to-lamp assembly gasket should be repositioned and resealed using the following procedure:

1. Remove the tail lamp door and lens and reposition the gasket on the lamp body assembly to insure adequate sealing. If the gasket is damaged, replace the gasket. See View A.
2. In addition, apply a bead of sealer around the periphery of the rear lamp door and reinstall the lens and lamp door to the lamp body. It is imperative that the gasket remain in position during installation of the lens to the body.

Trunk water leaks may occur between the rear lamp and lower back panel. This problem is caused by a poor seal between the rear lamp housing and lower back panel. When this condition is encountered, reseal the rear lamp to the lower back panel using the following procedure:

1. Remove the rear lamp assembly from the lower lock panel, and apply sealer to the sheet metal and around each rear lamp mounting hole. See View B.
2. Replace the rear lamp assembly to the lower back panel and water test to ensure proper sealing.

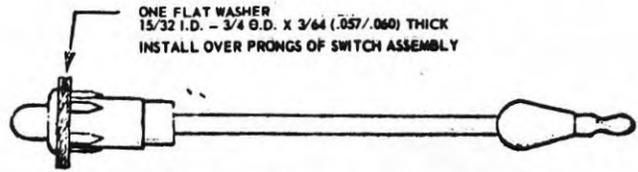

## GLOVE BOX LIGHT STAYS ON (1969 Mustang)

The glove box light may remain on, with resulting battery drain, if the glove box door does not move the switch plunger enough to open the switch contacts. To assure proper operation of the glove box light, a change was made in production during the month of September to provide adequate movement of the glove box light switch plunger.

To correct a vehicle exhibiting this condition, first inspect the glove box door for proper fit and correct as required. If correction of the glove box door fit does not eliminate the problem, the switch can be shimmed to provide additional plunger movement as described below.

1. Disconnect battery.
2. Remove glove compartment light switch.
3. Install washer over the switch retaining prongs.
4. Reinstall the switch and washer assembly.
5. Connect the battery and check for proper operation of the glove box light.

## IMPROPERLY TORQUED ENGINE MOUNTS (1968 Mustang with 8-Cylinder Engine)

A "clunk" type noise in the engine compartment and/or an improper functioning of the clutch or transmission shift linkage may be the result of loosened insulator-to-engine attaching bolts.

When diagnosing complaints of this nature it is essential to check engine mount bolt torque. The proper torque is 34-50 lb. ft. If the bolts do not meet this specification, they must be retorqued before proceeding to further diagnostic procedures.

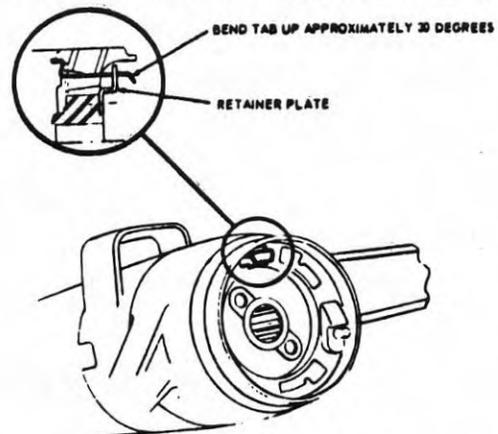

## HORN WILL NOT BLOW (All 1966 Mustangs)

Complaints of the horn not blowing when the horn ring is depressed in the six-o'clock position may be encountered on units produced prior to October 15, 1965. This problem is caused by improper horn ring contact in the steering column.

The problem can be corrected by bending the horn contact tab up approximately 30° to make proper contact.

If complaints of this nature are encountered, the following corrective steps should be taken:

1. Disconnect the battery.
2. Remove the horn ring.
3. Bend the contact tab up approximately 30° as shown.
4. Install the horn ring.
5. Connect the battery and test horn.

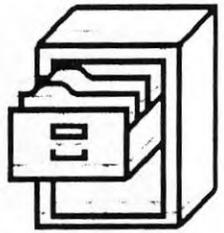

# CLASSIFIED

**FOR SALE:** 1965 Mustang Coupe 3 speed trans 6 cyl needs restoration. 1971-73 Mustang parts: right door, deck lid, bucket seats, fold down rear seats, console & gauges, plus misc parts. 79 & up Mustang parts: 4 speed trans, bucket seats, console, deck lid for coupe. 4 Goodyear G60X15 polyglas GT tires..

CALL TONY VIELGUT  
414-464-9079

**FOR SALE:** 1966 Mustang Fsbk, rear end smashed, no engine, all glass intact tinted and good interior ok..1965 Mustang Coupe 6 cyl runs great, needs floors. \$250.Set of chrome valve covers, New in the box, for 260, 289, 302, 351W \$65.

CALL SUZANNE CARLSON  
414-474-4696

**FOR SALE:** Mustang Body Parts. California rust free. Doors, fenders, hoods, deck lids. I have access to CA Mustang Salvage Yards. Parts for other makes available also.

CALL FRANK  
414-263-7892

**FOR SALE:** Late model Mustang 2 full tail light assemblies right & left. \$25. 4 bolt Craeger Mag wheels, fits 6 cyl Mustang \$75 set.

CALL BOB  
414-761-2007

**FOR SALE:** '71-73 Mustang Parts.Full console, driver door deluxe panel, dash pad (ginger), 1 pr sport mirrors.

CALL TIM (AFTER 6PM)  
414-548-0501

**FOR SALE:** 1966 Mustang Coupe. 289 automatic, power steering. 77000 miles. \$1995

CALL MRS LUEKER  
414-639-0177

**FOR SALE:** (2) P195/75R14 whitewall tires on late model 4 bolt Ford rims APX. 4000 mi. \$30/pair  
CALL JOHN (AFTER 5PM)  
414-476-6003

**WANTED:** 1982-86 Mustang rust free Coupe or convertible trunk lid.. 1983-84 Mustang premium stereo

CALL RON LUEPKE  
414-549-1838

**WANTED:** Mustang Pedal Car. Call after 6:00 with condition and asking price.

CALL TIM  
548-0501

**WANTED:** 1969 Mustang convertible with factory air prefer 351 V8 with deluxe interior.

CALL FRANK TROOST  
708-544-0916

**WANTED:** 1969 OR 1970 Air conditioning equipped dash pad, mint, any color. Will pay \$200.

CALL BOB  
774-4289

**SERVICE:** Snow Plowing, Salting, Snow removal. New plows 1 year parts and labor warranty. Full service of all brands of plows.

SNOW FIGHTERS (RICH BRUHN)  
414-425-4710

\*\*\*\*\*

TO PLACE AN AD IN THE FEEDBAG, SEND INFORMATION TO:  
BOB ZIMMERMANN

2307 W CARRINGTON AVE OAK CREEK WI 53154

**COFFEE  
BREAK**



# TAKE A BREAK

## A FOREIGN TRIP



ARRIVAL  
 AUBERGE  
 BAGGAGE  
 BILL  
 BRIDGE  
 BUILDING  
 CAMERA  
 CAPITAL  
 CASTLE  
 CHECK

CRUISE  
 DINING  
 EMBASSY  
 EUROPE  
 EXPRESS  
 FLIGHT  
 GARDEN  
 GATE  
 GUIDE  
 MARKET

PALACE  
 PLANE  
 RESORT  
 ROUTE  
 SITE  
 TAXI  
 TOUR  
 TOWER  
 VISA  
 WATCH



### Home Truths

"Maintenance-free" means that when it breaks, it can't be fixed.

—Quoted by Gene Brown in Danbury, Conn. *News-Times*

A closet is a place for hanging things after you run out of doorknobs.

—Doug Larson, United Feature Syndicate

You know you're getting old when you start riding a bike and your kids take the car.

—Michael L. Guido

The great thing about microwaves is now you can be a terrible cook in less time.

—Los Angeles Times Syndicate



### Answer Me This

Why does the person who runs five miles a day for exercise need a remote control for the TV?

—Doug Larson, United Feature Syndicate

How is it that at a hotel when you want to sleep, they want to make up the room at 7 a.m.? And when you want to check in, they still haven't made up the room at 7 p.m.?

—Robert Orben in *The Wall Street Journal*

Why is a Chinese fortune cookie written in English?

—Quoted by Flo Ashworth in Dawson County, Ga., *Advertiser*

Why has no one ever invented a compass that points in a useful direction—like toward the place where you parked your car?

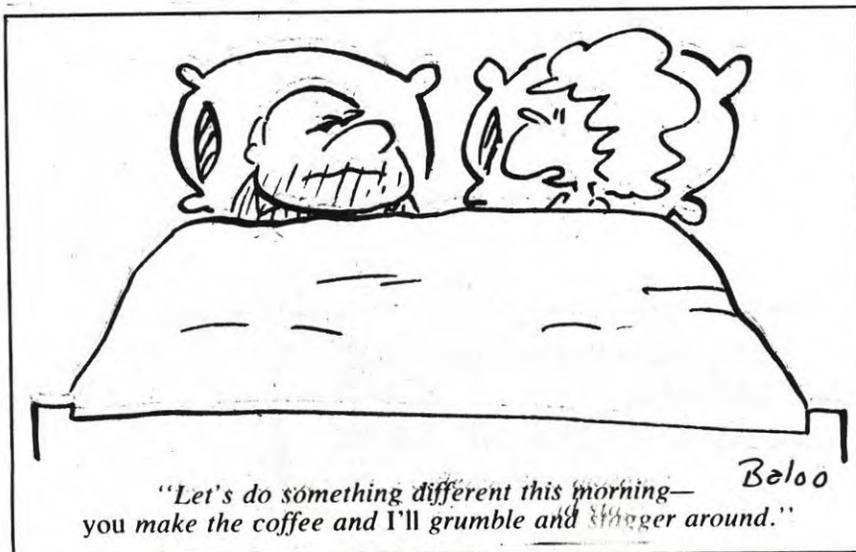



# The Feedbag

Publication of The Wisconsin Early Mustangers

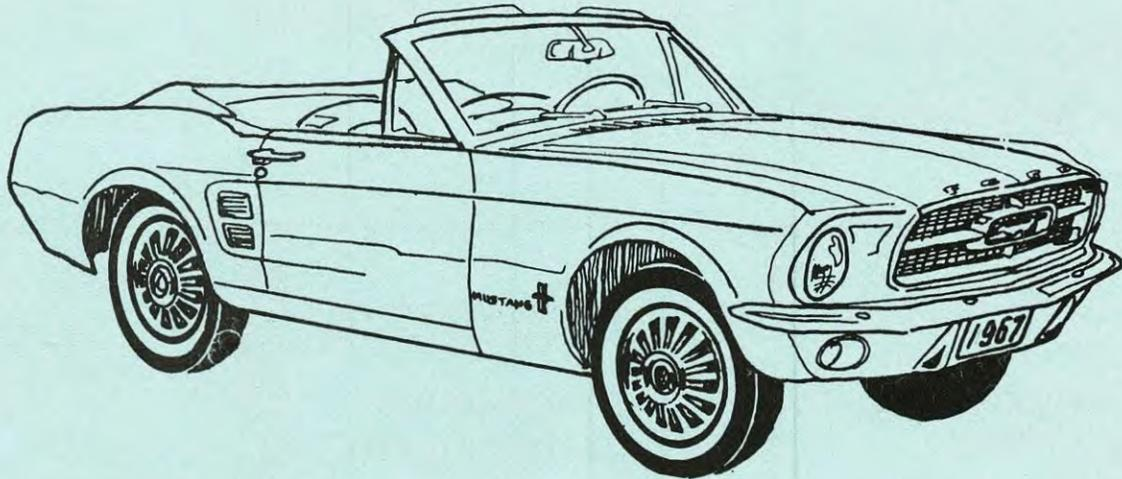

## THE FEED BAG NEWSLETTER OF THE WISCONSIN EARLY MUSTANGERS "A Few To Preserve The Best"

### OFFICERS

President .....	DICK DORIA .....	761-2267
Vice President .....	BOB ZIMMERMANN .....	761-2007
Secretary .....	MARY JO MILLER .....	282-7049
Treasurer .....	SHARON DORIA .....	761-2267

### BOARD MEMBERS

Chairman .....	DICK DORIA .....	761-2267
Show .....	SCOTT MOEN .....	646-3926
Ways & Means .....	SAL LORINO .....	961-7390
Activities (Trip) .....	DICK COYLE .....	691-3821
Picnic .....	LISA HOUSEY .....	UNLISTED
Special Events .....	DAVE YAHN .....	744-4352
Communications .....	DICK DORIA .....	761-2267
Technical Regional .....	PETER VOSS .....	529-2299
Technical National .....	MARK LIEN .....	461-9544

### CLUB ACCESSORIES:

CAPS (Blue, Black and Red) .....	\$ 5.00
SHIRTS — Golf Style With Logo (S,M,L,XL) .....	\$12.00
*WINDOW DECALS .....	\$ 1.00
*STICKERS .....	3 For \$ 1.00
*JACKET PATCHES — Swiss Embroidered .....	\$ 2.00 or 3 For \$ 5.00

\*Post Paid      Other Items Available As Produced

Send Check or Money Order To: **THE WISCONSIN EARLY MUSTANGERS**  
2511 West Carrington Avenue  
Oak Creek, Wisconsin 53154

The Headbay



**MARK'S**  
**AUTO BODY**  
 "QUALITY IS OUR REPUTATION"  
 Specializing In The Complete Restoration Of 1964 1/2-1968 Mustang Convertibles  
 NEW • USED • REPRODUCTION PARTS  
 7202 West Appleton Ave., Milwaukee, WI 53216  
 414-464-5500



**PETE'S AUTO BODY**  
 PETE YOSS, PROPRIETOR  
 HIGH QUALITY BODY & PAINT WORK  
 ALSO SPECIALIZING IN MUSTANG RESTORATION  
 W125 9861 A, North Cape Road  
 Hales Corners, WI, 53130  
 "THE MUSTANG SHOP"  
 (414) 529-2299



**Milwaukee Engine & Machine Inc.**  
 PHONE 321 • 6260  
 PAT EVANS  
 GENERAL MANAGER  
 7905 W. LINCOLN AVE.  
 MILWAUKEE, WIS. 53219



**DICK DORIA**  
**performance engineering**  
 SPECIALIZING IN PRODUCTS  
 2511 W CARRINGTON AVE  
 OAK CREEK, WISC 53154



761-2267

**SEAT COVER CO., INC.**  
 "SINCE 1945"  
 CLASSIC AUTO TRIM  
 COMPLETE AUTO UPHOLSTERY SERVICE  
 AUTOMOTIVE CARPETING - INSTALLED ON SO-IT-YOUNGKIT  
 SIMULATED VINYL & CONVERTIBLE TOP SPECIALISTS - SUNROOF  
 INSURANCE CLAIMS - FREE ESTIMATES  
 WHOLESALE & RETAIL  
 4325 S. HOWELL AVE.  
**DIAL 744-1907**



**THE WISCONSIN EARLY MUSTANGERS**  
 2511 WEST CARRINGTON AVENUE  
 OAK CREEK, WISCONSIN 53154



**FIRST CLASS MAIL**

**RICHARD DORIA 1**  
**2511 W CARRINGTON AVE**  
**OAK CREEK, WI 53154**