



**PRESERVATION**

**RESTORATION**

**ENJOYMENT**



## **MUSTANGERS**

**" A Few to Preserve the Best "**

**From the Prez :**

**July 3, 1992**

Well it finally happened. My girlfriend Tammy had her baby on June 28th, a girl, 8 lbs. 4 ozs. and healthy. Both Tammy and the baby are doing well. Unfortunately I had to miss the June meeting but some things can't be helped.

I talked with Jeanette on Tuesday to see how the meeting went. She told me that it went well and there was quite a bit of conversation regarding club activities, such as Over the Road Trips, One day Trips, and so on. Jeanette and I discussed the fact that we haven't been getting the participation that we had in the past. We aren't sure what the cause of this is but it is something that should be addressed in a serious way. As the president of your club, I want to know how you feel about this issue. I also want to know if the activities we plan are not to your liking. Every November we sit down before the regular meeting to plan out, tentatively, the next years club calendar. We invite anyone interested in helping plan the activities to attend that meeting. I know that November is still a ways away. Still, I don't think that this issue can wait that long. What I would like for you the membership to do is give me a call and let me know what your feelings are on this. My home phone number is ( 414 )-567-2622. I have an answering machine if I am not home, so please leave your name and phone number and the best time to get in touch with you. Please give the matter some thought and let me know how we can make the club activities more to your liking.

Well that's it for now. I'll look forward to hearing from all of you. Till next Month !

Keep on Stangin !!!

**P.S. Remember that the July meeting is  
being held at the Club Picnic on Aug. 2**

# FROM YOUR EDITOR

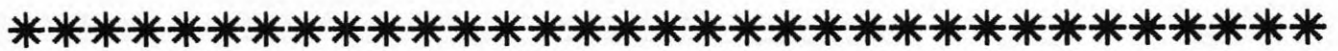
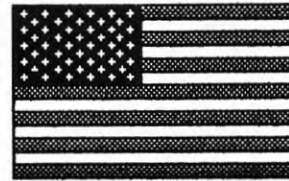

I am writing this portion of my article and directing it to the novice tube benders, like myself. I had recently decided to change my brake lines on my '65 convertible. The car is now 27 years old and still housed the original lines. Anyone familiar with the brake set up on a '65 or '66 Mustang knows that this is a single reservoir system. This means when the lines go so do your brakes. This system was changed in '67 when Ford designed a duel master cylinder system. Why did I wait so long? It was because the lines you previously worked with were straight and must be formed. Have you ever crawled under you Mustang and looked at the amount

of bends and turns in these lines? I did and this is what kept me from doing it until now.

I noticed late last year that California Mustang offered a preformed brake line for our cars. I quickly gave them a toll free call and asked for more information. The price for my '65 was \$115. I thought this a bit high at the time. The end result was that I purchased the lines and stored them until a few weeks ago. I finally got up the courage to set aside a week end to install them. Let me tell you I was never happier with a purchase of Mustang parts. The lines were perfectly formed. I would never have been able to form them that

precise. I could not believe the ease in which they went in. The only problem I had was trying to focus on the under body installation and this was due to bifocal glasses not the parts.

Califorina Mustang made a believer of me. They also offer complete preformed gas, vacuum, and transmission cooler lines.

So if you plan to do any major changes to these systems it is my recommendation to save a lot of grief check out the preformed lines first.

Until Next Month  
Fraternally Yours  
Bob Zimmermann



## WELCOME NEW MEMBERS

#346	Kevin Peterson	Jackson	WI
#347	Mike Wittig	Hales Cornes	WI
#348	Jan Goldberg	Waukesha	WI
#349	Don Mazar	Big Bend	WI
#350	Bob Rowley	Oconomowoc	WI
#351	Jennifer Elliot	New Berlin	WI
#352	Mark Spaude	Wis Rapids	WI
#353	James Murphy	Wauwatosa	WI
#354	Adrian Bonini	Shorewood	WI
#355	Mark Hebein	Saukville	WI

# MINUTES FROM MEETING HELD JUNE 29 1992

- The meeting was called to order by vice president Jeanette Roycraft at 7:30.
- Jeanette Roycraft read the minutes from the May meeting
- Treasurer Sharon Doria gave the clubs financial report.
- Representative from the Super 60's Ford club voiced concern that their shows at Town Ford and Sorens Ford did not receive coverage in our newsletter. The editor of the Feedbag indicated that he did not receive the requested information about the shows. A show flier for these two events will appear in the newsletter. Bob Zimmermann further requested that any info that you wish to have reproduced in the newsletter be sent to him directly.
- Dick Doria passed out medals for those who collected money for the March of Dimes Parade in which the club participated in. Congratulations to Sal Lorino for collecting the most money for this cause.
- A report was given on the House on the Rock OTR trip which took place in June. Only 3 cars and 5 people went on this outing. Dick Coyle put this trip together, but was forced to cancel portions of it due to lack of turnout. Those who went had a good time.
- The sparse turn out for our OTR trip to the house on the rock spurred conversation as how to get more involvement on these outings. It was stated that the planing of these events require lots of time and planning and the participation over the past years has been way down. It was recommended that a deposit be sent in well in advance to allow for better insight of participation
- The day trip previously planned for June 25 was called off due to lack of sign ups.
- Mike Ciepluch reported on the Cudahy 4th of July parade and the South Shore Parade. Anyone interested in attending should call Mike at 483-9539.
- A day trip is being planned for September 26th. Keep that date open.
- Dick Doria was contacted to supply a 1965 Mustang convertible to be photographed for use in a Snap ON tool calendar. A member present at the meeting volunteered.
- Lisa Housey announced that the permit for our annual picnic at Willowwood park has been procured. It was also announced that our July meeting will be held at the picnic. Date: August 2nd
- The committee chairmen of each area of the car show should turn in a list of names of members who assisted in their areas. This list should be forwarded to Scott Moen.
- The meeting was adjourned at 8:15.

**PLEASE NOTE THAT THE JULY MEETING WILL BE HELD AT OUR CLUB PICNIC AT WILLOWWOOD PARK ON AUGUST 2ND. THERE WILL NOT BE A MEETING AT WAUWATOSA SAVINGS AND LOAN THE LAST MONDAY OF JULY**

**SPECIAL THANKS TO 1st BANK S.E. FOR THEIR TROPHY DONATION TO OUR CAR SHOW. THEY WERE OMITTED FROM THE LAST MONTHS LIST OF DONORS.**

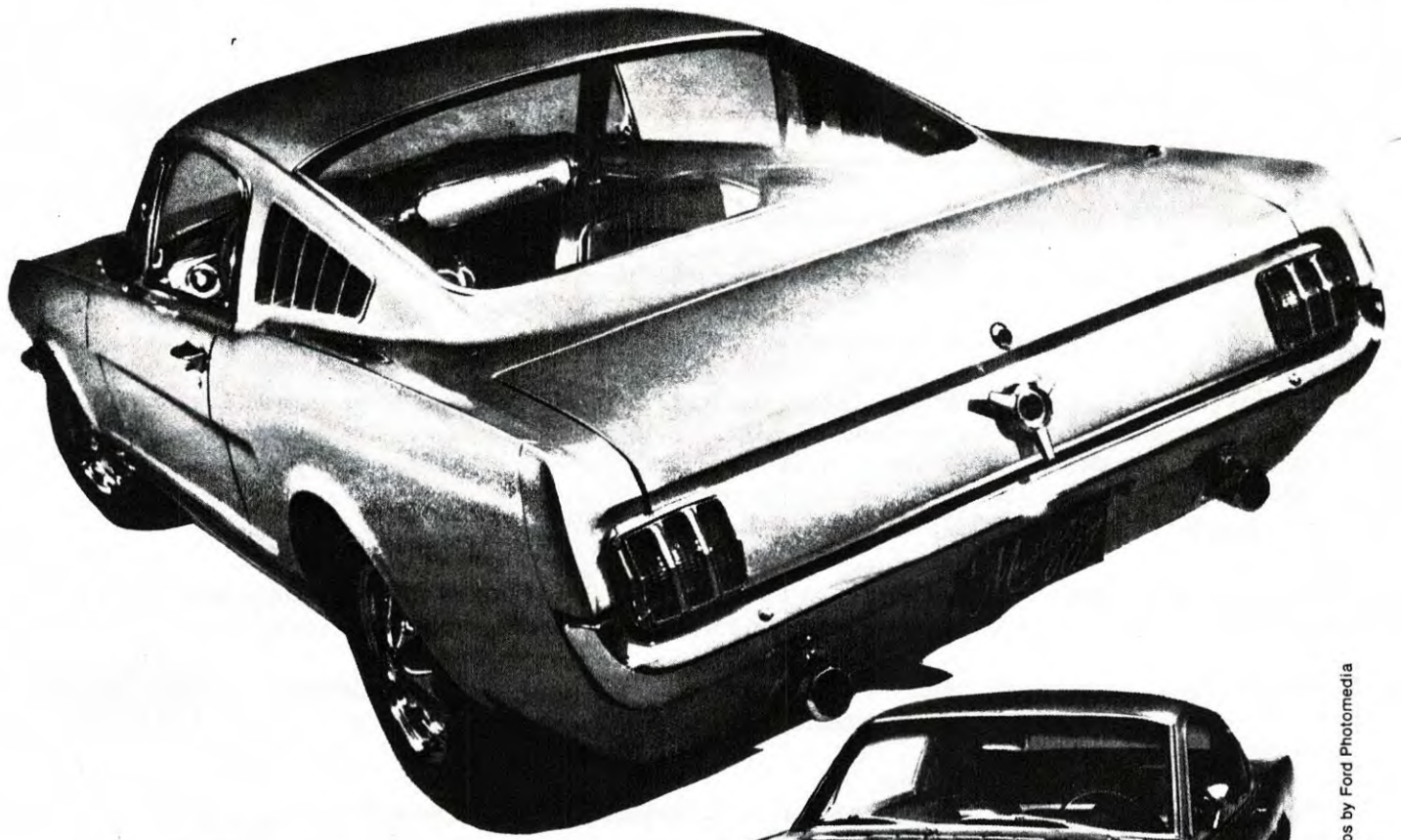

photos by Ford Photomedia

# I SPY



The Mustang 007 was gunned down before reaching production.

by Jim Smart

Throughout the 1960s, many Mustang prototypes were developed and built. Some survived the close scrutiny of Ford's top brass, making their way to production, while others went the way of the waste basket and scrap piles. The Mustang 007 was one prototype the motoring public would never see.

Inspired by the mid-1960's thirst for James Bond, *I Spy* and *Secret Agent Man*, the Mustang 007 was ready for action. Equipped with a Rally-Pac, overhead console, knock-off gas cap, styled steel wheels, retractable antenna, fog lamps and dual exhausts, this is one stallion that could keep up with the *Knight Rider!*

Obviously, the 007 was a concept

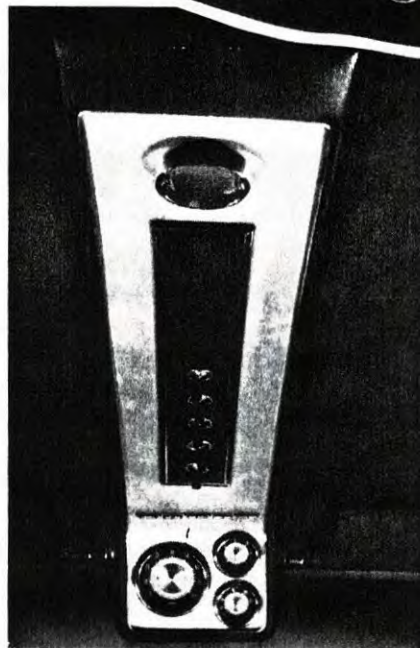

car, which no doubt explains why there were two tachometers, both in the overhead console and the Rally-Pac. In addition to the dual tachometers, there are a pair of water temperature gauges, a vacuum gauge (for the economy-minded spy), air conditioning to cool your pursuit, a convenience group consisting of five warning lights (flasher, low fuel, seat belts, hood ajar and door ajar) and an array of unknown toggle switches. In all likelihood, at least one toggle switch operated the fog lamps while another activated the smoke screen and oil slick. The three other switches obviously deployed drag chutes, a machine gun in the rear valance panel and, of course, the Martini dispenser.

Mustang 007 could have become a reality, but with limited appeal in the eyes of Ford management, the ultimate Grand Turismo spy Mustang was for *your eyes only.*





# The Wisconsin Early Mustangers

"A FEW TO PRESERVE THE BEST"

THE FEEDBAG

From the Pres. (retired)

June 29, 1992

Just a short note so you would not think I evaporated into thin air or something. I've been running around for Nabisco and others, like usual. Finally getting a chance to get my feet on the ground with the house and cars. In April Mike and Sherry presented us our second grandchild, a boy, Jonathan Michael Doria.

My commendation to Scott and the gang for the good job they are doing. Also, to the gang that made our show a big success. We were blessed with good weather, AGAIN! Nice to see many of you and your fine machinery out for that event.

The turn outs for our last couple of OTR's have been a little light. We would welcome input for short trips and one nighters. I wonder if we're missing the boat on what would interest the group. Or, maybe the cars are getting too nice to drive??????? If the latter is the case, may you spend eternity in a pile of burning junk tires!

We are working on the September 12 & 13 OTR. Hopefully, at tonight's meeting we'll come up with a destination. If we don't have enough interest we'll drop that one. In the mean time, we are going to start a sign up for our annual DOOR COUNTY TRIP. It will be held on October 9th, 10th and 11th this year. Come along even if you can only stay one night.

I have promised myself (and some others) to write a short series of articles about the conversion of the '79 Work 'Stang" to the '89 HO engine. Hopefully we can start that within the next few months. I'll tell you now, I don't regret doing it. It passed emissions with flying colors. It is a smooth combination with unbelievable torque. Most of all it has enough speed capability for your average nut. The biggest surprise is the gas mileage. Depending on how fast we drive, it gets between 22 and 27 MPG.

Got to go now. Keep in touch. Maybe we'll see you at the August 2nd picnic. Have a good Summer. Be safe, and of course "keep on 'stangin'".

 1

# Shop tips

Reprinted from technical and service bulletins published by Ford Motor Company, Autolite division.

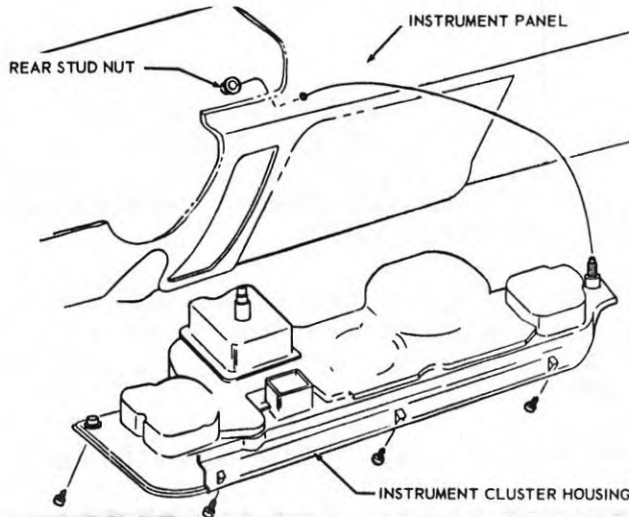

## INSTRUMENT CLUSTER REMOVAL (All 1967 Mustangs)

Instrument clusters on 1967 Mustang units have been cracked because of improper removal. When removing the instrument cluster make sure that you remove the right hand stud nut which retains the inboard end of the instrument cluster to the instrument panel. The 1967 Mustang Shop Manual contains complete removal instructions on page 15-36 under "Instrument Cluster Removal." Failure to adhere to this disassembly procedure may result in a cracked cluster mounting.

## PREMATURE SPARK PLUG FOULING (All 1968, 302, 390 and 428 CID Engines Except the 390-4V GT and 428 Cobra-Jet Packages)

The specified spark plug for all 1968 302, 390 and 428 CID Engines except the 390-4V GT and 428 Cobra-Jet packages has been revised from Autolite model BF-32 to BF-42.

This change, in response to complaints of premature spark plug fouling in cold weather applications, was effective at engine assembly plants approximately April 1, 1968.

Please revise all specification booklets and other spark plug application references to reflect this change.

## HIGH KEY OPERATING EFFORTS - LUGGAGE COMPARTMENT (All 1965 Mustang)

High key operating efforts, which in some cases might result in lock-out, may be experienced on the luggage compartment of some Mustangs.

The high efforts are caused by poor adjustment of the lock striker which can cause lock malfunction when it is set too low.

The lock striker should be adjusted by the following procedure:

Position the lock striker approximately 1/4-inch below the edge of the compartment opening and gently close the lid to insure that no interference exists. From this position, adjust the striker up or down to achieve a balance between lock operating effort and effective seal. When this point is reached, the edges of the lid should be approximately flush with the quarter panel opening.

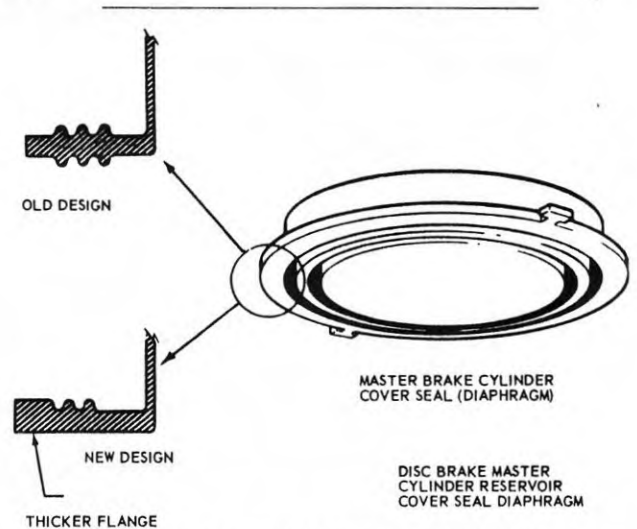

## DISC BRAKE MASTER CYLINDER RESERVOIR COVER SEAL DIAPHRAGM (All 1965-66 Mustangs with Disc Brakes)

Complaints of brake fluid leakage at the reservoir cover of master cylinder have been caused by the reservoir cover (diaphragm), not seating and sealing effectively. A new design seal (diaphragm), identified by the sealing ribs on the cover side only of the outer sealing surface, and by the increased thickness of the outer sealing flange, part number C5SZ-2167-A (Class "B") (same part as old or original seal), corrects this problem.

On vehicles built prior to February 1, 1966, remove the existing reservoir cover seal (diaphragm) and replace it with the new design seal. Be sure the sealing ribs of the diaphragm are located to the cover side only before placing cover and seal to reservoir.

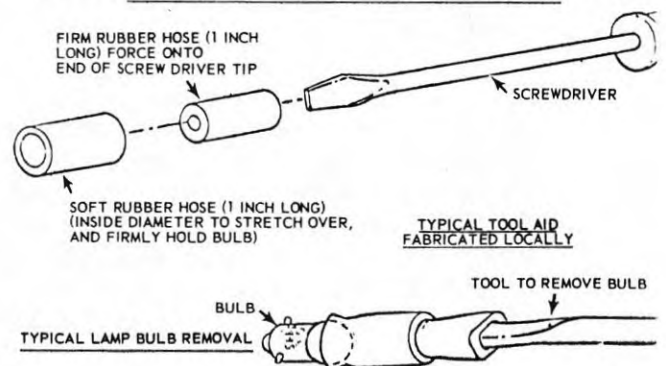

## FABRICATED TOOL FOR BULB REMOVAL FROM CONVENIENCE LAMP SOCKETS (All Models)

Reports have been received indicating that some dealers have encountered difficulty removing small bulbs from hard to reach areas.

To facilitate bulb removal in such areas, a tool aid may be fabricated locally. The tool assembly consists of a screw driver of appropriate size and two pieces of rubber hose, one of fairly firm durometer to fit tightly on the end of the screw driver and one of softer durometer with inside diameter of appropriate size to stretch over and firmly hold the bulb.



# CLASSIFIED

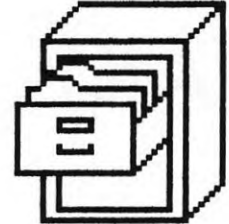

**FOR SALE:** 1966 Mustang Coupe. 289 autoTorquise. Less than 3000 miles on rebuilt engine. Restored and solid. Asking \$10,000

CALL JOE  
414-246-3925

**FOR SALE:** 1970 Mustang Fastback, Blue 302, 2BBL, Automatic, AC, PS, PB. 41,000 original miles. One family ownership. Southern car stored winters. No rust ever. Clean interior. New tires. Asking \$6500 OBO.

CALL BILL  
414-774-4710 (AFTER 5PM)

**FOR SALE:** 1973 Mustang conv complete. Needs restoration. Asking \$3750. Delivery additional. Roof & complete rear section for 1970 Mustang Fsbk. Can be cut at windshield posts and thru floor behind front seat. \$650.

WRITE TO  
JIM FEARS  
3451 BANNING ST  
DALLAS TX 75223

SEND YOUR ADS TO:  
BOB ZIMMERMANN  
2307 W CARRINGTON AVE  
OAK CREEK, WI 53154



## W.E.M. CALENDAR

DATE	DESCRIPTION OF EVENT
7/4	Cudahy Parade Meet at Pulaski and Swift @11:15 AM Club receives \$10 per car
7/11	Parade South Shore. Meet at Beecher and KK @ 11:15 AM.
7/17 - 7/18	Midwest Ford Club Nostalgia Days
8/2	Annual Picnic/July Monthly club meeting. 10 AM to ? Willowood Park .
8/15 - 8/17	North Woods SAAC Annual Elkhart Event
8/22	Midwest Ford Annual Car Show Antioch IL
8/31	Monthly club meeting. 7:30 PM Wauwatosa S & L
9/12 - 9/13	OTR Destination to be announced 1 nighter
9/26	OTR Day Trip Destination to be announced
9/28	Monthly club meeting. 7:30 PM Wauwatosa S & L
10/9 - 10/11	OTR Door County 2 nighter 1 night optional
10/25	Halloween Rally Mike Ciepluch to fill in details
10/26	Monthly club meeting. 7:30 PM Wauwatosa S & L
11/30	Monthly club & Planning meeting. 7:30 PM Wauwatosa S & L

# TAKE A BREAK



## NUMBER FIND

8	2	6	3	0	3	1	9	0	4	6	4	1	8	4
9	5	7	8	3	7	2	2	1	3	4	2	8	6	5
5	1	4	4	5	3	4	3	1	9	7	7	8	2	5
0	3	1	6	1	8	1	8	6	1	5	8	0	4	6
1	0	0	2	7	9	7	7	1	5	3	1	0	3	1
6	1	7	1	0	1	9	8	2	5	6	8	3	1	7
1	1	7	5	7	6	0	4	3	4	1	6	5	5	2
3	0	4	0	1	7	6	1	1	3	2	0	4	0	4
4	2	3	3	2	9	4	1	1	8	8	0	8	8	4
8	1	8	7	3	8	6	7	5	0	1	0	1	7	5
1	8	6	0	7	7	3	4	5	9	3	1	4	0	6
2	3	4	4	4	1	6	2	5	6	0	7	3	6	0
4	7	8	9	2	7	0	1	5	2	5	9	8	2	0
7	6	0	6	0	4	2	0	0	6	6	9	1	8	5
3	7	0	6	6	6	0	2	8	3	6	4	4	8	5

1002	1611	2877
3882	5039	6072
6288	7340	7474
10198	11814	15700
23820	26336	33317
49565	54670	56011
58446	64800	70666
71530	71746	86158
88114	89167	73459
110202	117421	130566
164116	164240	251072
255614	271655	328047
368478	381201	405831
418453	509131	510876
601433	630319	647536
660211	674107	730744
818738	887552	895016



## Classified Classics.

For-sale ad in a South Carolina weekly: "VCR. Like new. Never figured out."  
—Quoted by Bo Whaley in Dublin, Ga., *Courier-Herald*

In the Middletown, N.Y., *Times Herald-Record*: "LOST—Small, brown hamster. Children don't care. Cat is heartbroken."

In the DateMaker section of the Guilford, Conn., *Shore Line Times*: "Ugly, rude, insincere, untrustworthy, dishonest, slovenly, uneducated, SWM 24, hopes to entice exact opposite SWF 20-28 with romantic candlelight dinner."

## Comparatively Speaking

DIPLOMATS AND CRABS are creatures who move in such a way that it is impossible to tell whether they are coming or going.

—Quoted by Barnaby Conrad, III, in *More Than I Dreamed* by Malcolm S. Forbes (Simon & Schuster)

A JUICY RUMOR is to an adult what the prediction of a big snowstorm is to a kid. It promises so much fun that you just pray it's true.

—Tom Molloy in Skowhegan, Maine, *Reporter*

TRYING TO BALANCE a budget is like a game of pool: you're behind the eight ball, and all you see are a bunch of open pockets.

—Los Angeles Times Syndicate

BALONEY is the unvarnished lie laid on so thick you hate it. Blarney is flattery laid on so thin you love it.

—Bishop Fulton J. Sheen

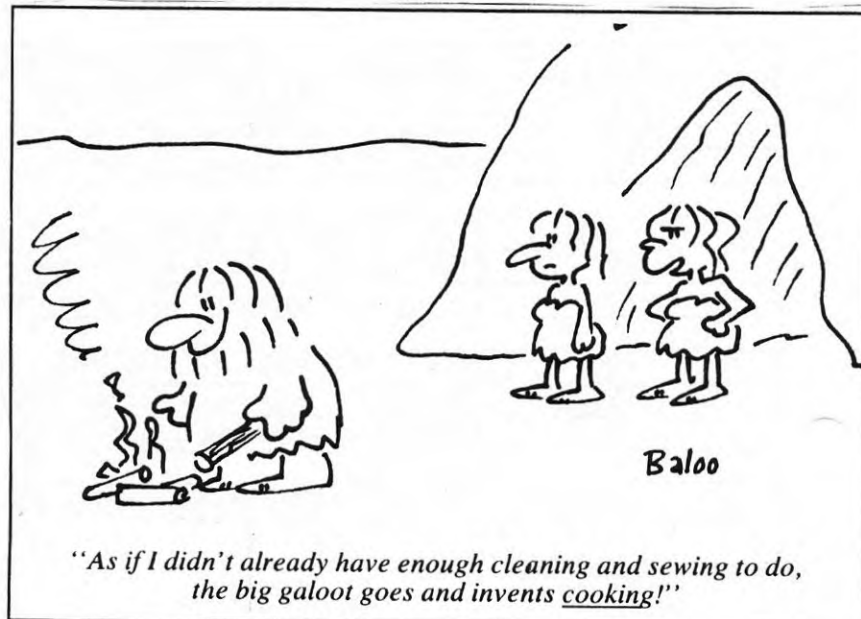



Name \_\_\_\_\_  
Address \_\_\_\_\_  
City, State, Zip \_\_\_\_\_  
Phone ( ) \_\_\_\_\_

Send \$5.00 per car (check or money order) to:  
Wisconsin Super 60's Ford Club  
c/o Mike Danihlik  
3847 E. Barnard Ave.  
Cudahy, WI 53110  
For info: 414-425-4710  
414-483-3048  
708-297-0083

I accept and assume full liability for any injury to me or my property, agents or employees at any time and from any cause on the premises of the show. I expressly release the management from any liability for such loss or injury, and agree to provide and pay for my own insurance.

Model \_\_\_\_\_ Year \_\_\_\_\_ Signature \_\_\_\_\_

**SOERENS**   
and the  
**WISCONSIN SUPER 60's FORD CLUB**



present the eleventh annual

# ALL FORD ROUND-UP CAR SHOW

All Ford-built Vehicles Welcome

**SUNDAY**  
**JULY 19, 1992**  
*(Rain or Shine)*

**9:00am to 4:00pm**

Goodie Bags & Dash Plaques to first 125 Entries

**Long Distance Award**  
(Point of origin within last 48 hours)

**Best of Show Award**

**Participant Voting**

**Show Cars Must Register by 12 noon**

**Balloting Ends at 2:00pm**

**Registration Fee - \$7.00**

(Pre-registration before July 12 - \$5.00)

**-no passenger or spectator fees-**



(Enter at far West entrance on Capitol Drive)

**Refreshments and Food Available**  
**Music by "Wolfman" Knapp of 39 AND HOLDING**

**3 Places Awarded in each of 18 classes**

**A All Models 1903-51**  
**B Full Size 1952-59**  
**C Full Size 1960-64**  
**D Full Size 1965-70**  
**E Midsize to 1965**  
**F Midsize 1966-76**  
**G Boss/Shelby All Years**  
**H Mustang 1964-66**  
**I Mustang 1967-73**  
**J Mustang 1974-present**

**K Thunderbird 1955-57**  
**L Thunderbird 1958-76**  
**M Full Size 1971-present**  
**All Others 1977-present**  
**N Cougar 1967-73**  
**O Modified All Years**  
**P Custom All Years**  
**Q Special Interest**  
**All Race Vehicles**  
**R Trucks/Vans 1951-present**

\*Note: 3 modifications from stock will put a vehicle into the modified or custom class. Class placement is at the discretion of the Show Committee. Don't see a class for your car? Clubs pre-registering a minimum of 8 cars will have their own class. Contact us!



and the **WISCONSIN SUPER 60's FORD CLUB**

present the FIFTH annual



**ALL  SHOW**

All Ford-built Vehicles Welcome

**SUNDAY,  
AUGUST 16, 1992**  
*(Rain or Shine)*

**9:00am to 4:00pm**

**Registration Fee - \$7.00**  
*(Pre-registration before August 9 - \$5.00)*

**-no passenger or spectator fees-**

**Welcome Falcon Nationals Attendees!**  
The Falcon Nationals are being held in Milwaukee Aug. 13-15  
*(Two Stock Falcon Classes have been added)*

**Goodie Bags & Dash Plaques to first 125 Entries**

**Long Distance Award**  
*(Point of origin within last 48 hours)*

**Best of Show Award**

**Dealer's Choice Award**

**Participant Voting**

**Show Cars Must Register by 12 noon**

**Balloting Ends at 2:00pm**

Held at

**HAL LUCAS'  inc.**

RACINE, WISCONSIN

5910 Washington Avenue • Racine, WI • 53406

*(5 miles east of I-94 on Highway 20)*

**Refreshments and Food Available**  
**Music by "Wolfman" Knapp of 39 AND HOLDING**

**3 Places Awarded in each of 20 Classes**

- A All Models 1903-31
- B All Models 1932-51
- C Full Size 1952-59
- D Full Size 1960-64
- E Full Size 1965-70
- F Midsize to 1965
- G Midsize 1966-76

- H Boss/Shelby All Years
- I Mustang 1964-66
- J Mustang 1967-73
- K Mustang 1974-present
- L Thunderbird All Years
- M Full Size 1971-present
- All Others 1977-present

- N Cougar 1967-73
- O Modified All Years
- P Custom All Years
- Q Special Interest/Race Vehicles
- R Trucks/Vans 1951-present
- S Falcon 1960-63
- T Falcon 1964 & up

\*Note: 3 modifications from stock will put a vehicle into the modified or custom class. Class placement is at the discretion of the Show Committee. Don't see a class for your car? Clubs pre-registering a minimum of 8 cars will have their own class. Contact us!

**REGISTRATION FORM**

Name \_\_\_\_\_  
Address \_\_\_\_\_  
City, State, Zip \_\_\_\_\_  
Phone (        ) \_\_\_\_\_

Send \$5.00 per car (check or money order) to:  
Wisconsin Super 60's Ford Club  
c/o Mike Danihlik  
3847 E. Bamard Ave.  
Cudahy, WI 53110

For info: 414-425-4710  
414-483-3048  
708-297-0083

I accept and assume full liability for any injury to me or my property, agents or employees at any time and from any cause on the premises of the show. I expressly release the management from any liability for such loss or injury, and agree to provide and pay for my own insurance.

Model \_\_\_\_\_ Year \_\_\_\_\_ Signature \_\_\_\_\_

Midwest Ford Club and Lyons-Ryan Ford  
present their seventh annual

**Model Car Show**  
\$1.00 per Entry  
2 Classes



Music by  
39 & Holding

**and Swap Meet**  
All Fords, Lincolns, and Mercurys Welcome

**Sunday, Aug. 23, 1992**  
*(Rain or Shine)*

**9:00 a.m. to 4:00 p.m.**

**Goodie Bags to First 160 Entries**

**Over 70 Trophies Awarded in 25 Classes**  
(Classes on Reverse Side)

**Show Cars Must Register by 12:00 Noon**  
**Participant Voting**  
**Balloting Ends at 2:00 p.m.**

**Registration Fee - \$7.00**  
(Preregistration before Aug. 4 - \$5.00)

Held at



Located on Rt. 173 in Antioch, IL  
between Rts. 45 and 83

**Swap Meet Information**  
**Indoor/Outdoor**  
**10'x15' Spaces**  
**\$10.00**

**Refreshments Available**

**REGISTRATION FORM**

Name \_\_\_\_\_

Address \_\_\_\_\_

City \_\_\_\_\_ State \_\_\_\_\_ Zip \_\_\_\_\_

Phone \_\_\_\_\_

Swap Meet Space—\$10.00 Indoor \_\_\_\_\_ Outdoor \_\_\_\_\_  
Car Show—\$7.00  
(Before August 4—\$5.00)

Total \_\_\_\_\_

Model \_\_\_\_\_ Year \_\_\_\_\_

**Send Check or Money Order To:**  
Midwest Ford Club  
2721 Gilboa Avenue  
Zion, IL 60099

For Information Call:  
John L. — 708/746-9149  
Pat S. — 708/395-6509

**I accept and assume full liability for any injury to me or my property, agents or employees at any time and from any cause on the premises of the show. I expressly release the management from any liability for such loss or injury, and agree to provide and pay for my own insurance.**

Signature \_\_\_\_\_

## 1992 Classes

A	Ford, Mercury, Lincoln Stock 1903-1948	N	Mustang Stock 1974 - Present
B	Ford, Mercury, Lincoln Stock 1949 - 1959	O	Shelby & Boss Mustang Stock All Years
C	Ford Only Stock 1955 - 1956	P	Falcon Stock All Years
D	Ford, Mercury, Lincoln Stock 1960 - 1964	Q	Thunderbird Stock All Years
E	Ford, Mercury, Lincoln Stock 1965 - 1970	R	Cougar Stock All Years
F	Ford, Mercury, Lincoln Stock 1971 - 1979	S	Truck & Van Stock All Years, All Models
G	Ford, Mercury, Lincoln Stock 1980 - Present	T	Retractable All Years
H	Midsize Ford, Mercury Stock 1960 - 1965	U	Modified All Years, All Models
I	Midsize Ford, Mercury Stock 1966 - 1971	V	Custom All Years, All Models
J	Mustang Stock - Open 1964 1/2 - 1966	W	Street Rod All Years
K	Mustang Stock - Closed 1964 1/2 - 1966	X	Special Interest All Years, All Makes, All Models
L	Mustang Stock 1967 - 1970	Y	Custom/Modified Truck All Years
M	Mustang Stock 1971 - 1973		

# The Feedbag

Publication of The Wisconsin Early Mustangers

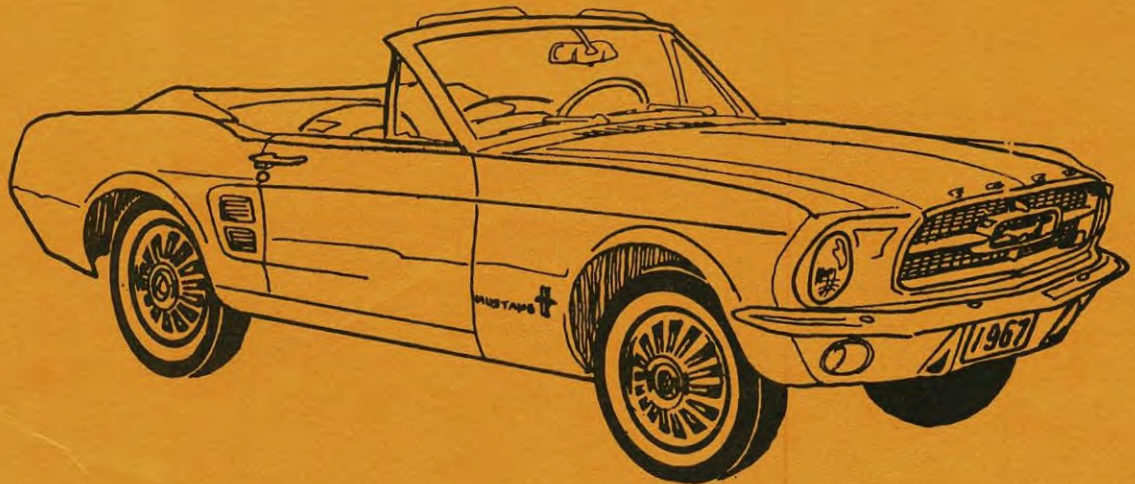

## THE FEED BAG

Newsletter of the Wisconsin Early Mustangers

*"A Few To Preserve The Best"*

### OFFICERS

President .....	SCOTT MOEN .....	(414) 646-3926
Vice President .....	JEANETTE ROYCRAFT .....	444-2240
Secretary .....	MARY JO MILLER .....	282-7049
Treasurer .....	SHARON DORIA .....	761-2267

### BOARD MEMBERS

Chairman .....	DICK DORIA .....	(414) 761-2267
Show .....	PAUL SPERBECK .....	544-0784
Ways & Means .....	DICK DORIA .....	761-2267
Activities .....	DICK COYLE .....	691-3821
Picnic .....	LISA HOUSEY .....	Unlisted
Communications .....	DICK DORIA/BOB ZIMMERMANN .....	761-2007
Technical .....	Pete Yoss .....	529-2299
Technical .....	MARK LIEN .....	461-9544

### CLUB ACCESSORIES:

Caps (Black, Blue, Red; Green and Yellow) .....		\$ 5.00	
Shirts — Golf Style with Logo (S, M, L, XL) .....		\$12.00	
*Window Decals .....	\$ 1.00	*Stickers .....	3 For \$ 1.00
Jacket Patches — Swiss Embroidered .....		\$ 2.00 or 3 For \$ 5.00	
Genuine Brass Buckles with W.E.M. Inlay .....		\$18.00	

\* = Postpaid

Send Check or Money Order To: **THE WISCONSIN EARLY MUSTANGERS**  
2511 West Carrington Avenue  
Oak Creek, Wisconsin 53154

# The Hobby



**MARK'S**  
**AUTO BODY**  
 "QUALITY IS OUR REPUTATION"  
 Specializing in The Complete Restoration of 1964 1/2-1968 Mustang Convertibles  
 NEW • USED • REPRODUCTION PARTS  
 7202 West Appleton Ave., Milwaukee, WI 53218  
 414-464-5500

**PETE'S AUTO BODY**  
 PETE YOSS, PROPRIETOR  
 HIGH QUALITY BODY & PAINT WORK  
 ALSO SPECIALIZING IN MUSTANG RESTORATION  
 W125 9861 A, North Cape Road  
 Hales Corners, WI, 53130  
 (414) 529-2299  
 "THE MUSTANG SHOP"



**Milwaukee Engine & Machine Inc.**  
 PHONE 321 - 6260  
 PAT EVANS  
 GENERAL MANAGER  
 7905 W. LINCOLN AVE.  
 MILWAUKEE, WIS. 53219

**DICK DORIA**  
**performance engineering**  
 2511 W CARRINGTON AVE  
 OAK CREEK, WISC 53154  
 SPECIALIZING IN  
**Ford**  
**PRODUCTS**

**761-2267**

**SEAT COVER**  
**CO., INC.**  
 "SINCE 1945"  
**CLASSIC AUTO TRIM**  
 COMPLETE AUTO UPHOLSTERY SERVICE  
 AUTOMOTIVE CARPETING - INSTALL OR SO-IT-YOURSELF KIT  
 SIMULATED VINYL & CONVERTIBLE TOP SPECIALISTS - SUNHOOPS  
 INSURANCE CLAIMS - FREE ESTIMATES  
 WHOLESALE & RETAIL  
 4325 S. HOWELL AVE.  
**DIAL 744-1907**



**THE WISCONSIN EARLY MUSTANGERS**  
 2511 WEST CARRINGTON AVENUE  
 OAK CREEK, WISCONSIN 53154



**FIRST CLASS MAIL**

**RICHARD DORIA 1**  
**2511 W CARRINGTON AVE**  
**OAK CREEK WI 53154**

