

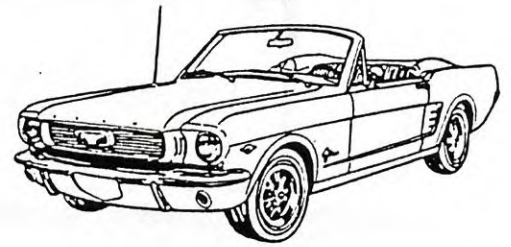

**PRESERVATION**

**RESTORATION**

**ENJOYMENT**



**MUSTANGERS**

**" A Few to Preserve the Best "**

**From the Prez :**

**May 29, 1993**

Well the 11th Annual Wisconsin Early Mustangers Show has come and gone. The turn out was good considering the weather was playing games with us. You know what they say, "This is Wisconsin, if you don't like the weather . . wait five minutes and it'll change." We had 150 cars that showed up and a good turn out for the swap meet. I trust everyone enjoyed themselves just as Tammy and I did. I'd like to say how much the club and I appreciate the people who pitched in and helped make this show a success. I also would like to thank Gene Schwister and Schwister Ford for their help and support as well as all the companies who helped with the trophy donations. Let's look forward to next years show as we celebrate the Mustang's 30th Birthday !

There is a sign up sheet in the newsletter for the Day Trip that we will be taking on June 26th. This should prove to be a once in a lifetime opportunity to see one of the largest Exotic Ford Car collections in existence. We will be going to see George Stauffer's collection in Blue Mound, WI. We will also be stopping at RPM's for lunch on the way. This is a fifties style diner with a superb collection of antiques and auto related collectibles. If you can attend we would love to have you along.

Please start to look ahead to the upcoming Shows, Day and Over the Road Trips. We will be starting to collect deposits for the Over the Road trips next month. As in past years, the reserved spots will go quickly. Don't miss out on the fun. I hope everyone has a great June ! Until next month . . . .

Keep on Stangin !

---

## FROM YOUR EDITOR



### WEM CAR SHOW

Our 1993 Car show and swap is now history. This years show made me realize what a die hard car enthusiast is really made of. Like watching the Packers play football in 10 degree below zero weather, we had a good turn out for our show even in the rain. The entries were down about 50 cars from last years show, but none the less we still realized a profit of \$963. A lot of hard work and effort is spent putting on a show of our caliber. I think anyone who helped in any capacity can hold their head up high and be proud of the fruits of their efforts. The day started out overcast with a slight mist. It did stop misting for

a bit but remained dreary. The cars started to arrive for registration at about 7:30. Early signs indicated that we were headed for a disaster. By 8:30 only 10 cars had registered. This was quite a bit behind the pace of previous years. Things started to pick up around 9:00 and we keep going at a fairly steady pace. The weather became pleasant for a while, but along about 1:00 it started to rain hard, causing the convertible owners to scurry out to put up their tops. The good news is that during the downpour people were forced inside which aided the revenue for our concessions. The lower registration, 159 cars in all,

allowed the ballot team to have their tallies done earlier. We held our drawings and award ceremonies a bit earlier than previous years. Then it was time for the cleanup crew to man their brooms. Hindsight tells me that the type of day we had for our show was probably beneficial in the long run. We always were wondering what would happen to the club treasury if we had a rainout and had to absorb all the expenses. This only goes to show that those who love old iron are made up of iron themselves.

Until Next Month,  
Fraternally Yours  
Bob Zimmermann

---

## THANK YOU THANK YOU THANK YOU THANK YOU THANK YOU

The Wisconsin Early Mustangers would like to acknowledge and thank the following concerns for their support through trophy donations, door prizes, and goodie bag donations. We ask that our members patronize the following in gratitude for their help. A special thanks to Schwister Ford for the use of their facility and the donation of our main door prize, a 13" Color TV.

### TROPHY DONATIONS

Jax Seat Covers  
Mufflers & Pipes  
Schan Tax Service  
Dick Doria Performance Engineering  
Marshall & Ilsley Bank of Menomonee Falls

### DOOR PRIZES

Schwister Ford  
Billings Rebuilding  
Joe Carini Lincoln Mercury

### GOODIE BAG DONATIONS

Environmental Test Systems  
1st Bank Southeast  
Simple Green

Flitz international  
Go Jo Industries  
Ford Buyers Guide

Locktite Corp.  
W/D 40  
Channel Lock

## MINUTES FROM MEETING HELD MAY 24

- The meeting was called to order by president Moen at 7:35 PM.
- No minutes were read from the April meeting.
- Treasurer report was given by Dick Doria .
- Dick Doria gave the final financial tally from the car show. Although the unfavorable weather had an impact on profits the club still realized a net gain of \$963.
- The June 26th one day OTR trip is a go. The destination will be Stoeffers Auto Collection at Blue Mounds WI. An eating stop is planned at RPM'S in Mount Horeb. Meet at Wauwatosa S&L at 8:30 or McDonalds on hwy 83 and I-94 at 9:00.
- The one nighter for August 28 & 29 to the Wisconsin Dells Car show is still on. More information will be passed along as soon as the details are set.
- The one night trip planned for June 12th was canceled as no destination was planned. The members were asked for their assistance in planning one niters.
- Our annual car show and swap went off well in spite of the weather. We had a total of 159 cars register for the show. There were only 9 no shows. All vendor concession, swap area and registration did well considering. Thanks to all of you who helped pull it off.
- The destination for the Saturday September 9th day trip is set for Bob Perkins auto collection in Juneau WI. More info closer to come.
- Bob Zimmermann reported that we now have a source to reproduce photos for the club newsletter thanks to member Adrian Bonnini. If you have any trip photos or photos of club functions please send them in to Bob with a brief explanation. He will also accept photos of your car with a story to be used in the Car of the Month feature.
- It was reported that volunteers came forth to help set up and organize the Halloween Rally. Make a point to plan to participate. A lot of work goes into the planning of a rally. The more cars that take part the more fun the rally. Trophies will be awarded.
- The August picnic is slated to be a member reunion outing. Dick Doria and Bob Zimmermann will peruse the inactive roster and invitations will be sent out to past members who took an active role in our club. It was suggested that we hold a picture taking session our cars at the picnic.
- The meeting was adjourned at 8:10 PM.

---

### DAY TRIP JUNE 26TH

A one day trip is set for June 26th. The destination will be the Stoeffers Auto collection in Blue Mounds WI. See a dazzling collection of Mustang Cobras and GT's. A food stop is planned for RPM's in Mount Horeb. RPM's has a fine display of nostalgic 50's and 60's memorabilia.

Meeting places are set for Wauwatosa S&L at 8:30AM. This group will link up with a group meeting at McDonalds on Hwy. 83 and I-94 at 9:00AM. If you plan on attending contact Scott Moen.

SCOTT MOEN  
1122 HUBBARD CT  
OCONOMWOC, WI 53066  
PHONE 567-2622



## 1993 CLUB CALENDAR



6/20/93		"Fathers Day" Rod, Custom, and Classis car show. Borchard Speed Automotive
6/26/93		W.E.M day trip. Blue Mounds WI. Stoeffers Auto Collecton
6/28/93		Monthly Club Meeting. 7:30PM Wauwatosa S&L Meeting room.
7/9/93	7/11/93	Iola Old Car Show & Swap. Iola WI
7/16/93	7/17/93	Nostalgia Days held in Zion Illinois. Contact Kathy Lerner for details.
7/18/93		Super 60's Ford show held at Sorens Ford.
7/26/93		Monthly Club Meeting. 7:30PM Wauwatosa S&L Meeting room.
7/30/93	7/31/93	Hot Summer Nights held in Lafayette Indiana.
8/1/93		Elkorn Summer Little Carlisle. Walworth County Fairgrounds
8/8/93		Super 60's Ford show held at Towne Ford.
8/15/93		Annual Club picnic and reunion.
8/22/93		Midwest Ford show in Antioch Illinois.
8/28/93	8/29/93	W.E.M. Over the Road Weekender. Wisconsin Dells Car Show.
8/30/93		Monthly Club Meeting. 7:30PM Wauwatosa S&L Meeting room.
9/11/93		W.E.M Day trip. Juneau WI. Bob Perkins Auto Collection
9/23/93	9/26/93	Joint OTR trip with the Midwest Ford Club. Destination Dearborn Michigan.
9/25/93	9/26/93	Jefferson Fall Little Carlisle. Jefferson Fairgrounds.
9/25/93	9/26/93	Lake Geneva Classic Car Rally, Poker Tour. Benefit childhood cancer.
9/27/93		Monthly Club Meeting. 7:30PM Wauwatosa S&L Meeting room.
10/8/93	10/10/93	Annual OTR Trip to Door County.
10/25/93		Monthly Club Meeting. 7:30PM Wauwatosa S&L Meeting room.
10/30/93		Halloween Ralley.
11/29/93		Monthly Club Meeting. 7:30PM Wauwatosa S&L Meeting room.

*Do you have a date for an event you would like to place on the club calendar ?? If so please forward to Bob Zimmermann and it will appear on the next calendar print out*

# 1993 SHOW WINNERS

DESCRIPTION	NAME	DESCRIPTION	NAME
<b>MUSTANG 1964-1966 CONVERTIBLE</b>	1st Wavne Kabitske 2nd Sal Lorrno	<b>SHELBY 1965-1970 ALL MODELS</b>	1st Phil Czarnecki 2nd Chuck Burnett 2nd Lance Tarnature
<b>MUSTANG 1964-1966 COUPE</b>	1st Gene Myers 2nd Jeff Kneipper	<b>COUGAR 1968-1992 ALL MODELS</b>	1st Jim Severson 2nd Doug Wankowski
<b>MUSTANG 1964-1966 FASTBACK</b>	1st Jim Majerus 2nd Roger Nickolas	<b>FORD/MERC/LINCOLN 1903-1939 ALL MODELS</b>	1st Bud Armstrong 2nd Marc Micale
<b>MUSTANG 1967-1968 CONVERTIBLE</b>	1st Jon Nilsen 2nd Dale Steege	<b>FORD/MERC/LINCOLN 1940-1959 ALL MODELS</b>	1st Robert Maro 2nd Mike Wheatley
<b>MUSTANG 1967-1968 COUPE</b>	1st Brian Popowski 2nd Steve Klein	<b>FORD/MERC/LINCOLN 1960-1963 ALL MODELS</b>	1st Rich Blauvelt 2nd Cheryl Damrow
<b>MUSTANG 1967-1968 FASTBACK</b>	1st Gail Dweyer 2nd Dick Coyle	<b>FORD/MERC/LINCOLN 1964-1966 ALL MODELS</b>	1st Del Krieger 2nd George Balling
<b>MUSTANG 1969-1973 CONVERTIBLE</b>	1st Mary Jo Miller	<b>FORD/MERC/LINCOLN 1967-1970 ALL MODELS</b>	1st Dave Moots 2nd Mike Chucka
<b>MUSTANG 1969-1973 COUPE/FSBK</b>	1st Jeanette Roycraft 2nd Marlene Witczak	<b>FORD/MERC/LINCOLN 1971-1993 ALL MODELS</b>	1st Gary Zaeske 2nd Frank Oliver
<b>MUSTANGS(MODIFIED) 1964-1973 ALL MODELS</b>	1st Bob Mahoney 2nd Randy Kropusek	<b>THUNDERBIRD 1955-1957 ALL MODELS</b>	1st Jim Rugg 2nd Dave Malmquist
<b>MUSTANG 1969-1973 BOSS 302, 351</b>	1st Scott Fleming 2nd Tony Vielgut	<b>THUNDERBIRD 1958-1993 ALL MODELS</b>	1st Jim Rugg 2nd Ed Uhl
<b>MUSTANG 1969-1973 MACHS</b>	1st Dennis Foltz 2nd Chuck Spencer	<b>FORD TRUCKS/VANS ALL YEARS 2WD/4WD</b>	1st Suzanne Goerg 2nd Peter Bungert
<b>MUSTANG 1974-1993 COUPE/HATC</b>	1st Gloria Luepke 2nd Tom Steepy	<b>FALCON 1960-1969 ALL MODELS</b>	1st John Lerner 2nd Brian Gatzow
<b>MUSTANG 1983-1993 CONVERTIBLE</b>	1st Terry McCoy 2nd Linda Kender	<b>SPECIAL INTEREST 1898-1992 INCLUDES EDSEL</b>	1st Neil Paton 2nd Robert Jean

**BEST OF SHOW : Dave Strucsynski 1966 Mustang Coupe**



# CLASSIFIED

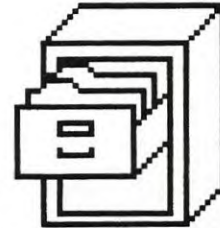

FOR SALE: 1966 Mustang Convertible. Red with white top. Complete professional restoration inside and out. Winner of many first place trophies. Asking \$17,000

CALL SAL LORINO  
769-0700

---

FOR SALE: 1973 Red Mustang Mach 1 with 302 & automatic trans. AM/FM radio with cassette. body restored in 1981.

Asking \$5,000 (negotiable).

CALL ROBERT BUTT  
375-9132

---

FOR SALE: I still have a few restorable bodies to replace that "rust bucket of yours. The best of them are being bought up so make a decision soon to not put another patch on your Mustang.

WRITE JIM FEARS  
3451 BANNING ST  
DALLAS TX 75233

---

FOR SALE: 1970 Mustang Coupe. Texas body, no rust. 351 Windsor. Sell as is or will restore \$2500. 1969 Mach 1. 351 2V. Automatic. Power steering and brakes. New dual exhaust. Restoration started. Texas car. As is or restore. 1973 Mustang convertible. Project car. 351 2V Power steering and brakes. Needs total restoration. Make offer. 9" Posi rearends 2.79, 3.25, 3.7, 5.13.

CALL PETE  
529-2299

---

FOR SALE: 1971 Mach 1. 351C, 3SPD,. Needs restoration. \$750. Front tub complete no rust for 1971-73 \$100. NOS Mach 1 style hood \$400, includes freight to Milwaukee. Fenders, doors, glass.

CALL FRANK  
414-263-7892

---

SEND YOUR ADS TO:  
BOB ZIMMERMANN  
2307 W CARRINGTON AVE  
OAK CREEK, WI 53154

If ad is received by the club meeting it will appear in the next edition

# Shop tips

Reprinted from technical and service bulletins published by Ford Motor Company.

## DOOR WINDOW RATTLE AND GLASS INSTABILITY (1965 Mustang - All Models)

During the initial incorporation of the "welded in" down stop bracket for the new "down" stop bumper, the new bracket was too high and would not allow the glass to be dropped sufficiently to permit installation of the belt line weatherstrip. A new design bracket was incorporated in production on January 4, 1965, however the stop bumper was not incorporated in production until February 8, 1965.

Owners encountering door window rattles and/or glass instability problems on units built prior to January 4, 1965, should use the corrective procedure outlined in Article 92. If these problems are encountered on units built from January 4, 1965 to February 8, 1965, a bumper should be procured, reworked and installed using the following procedure.

1. Remove the door trim panel and observe the inside of the door to verify that the stop bracket has been installed. Loosen the sector of the door.

2. Procure a C3AZ-6221762 bumper and rework as shown. Install the reworked bumper into the stop bracket in the bottom of the door.

3. Lower the window to the full "down" position and set the door window sector gear down stop firmly against the regulator sector gear.

4. Slam the door several times to verify the effectiveness of the repair and reinstall door trim.

Parts required to perform this correction are:

Part Number	Part Name	Class	Quantity
C3AZ-6221762	Bumper	C	as required

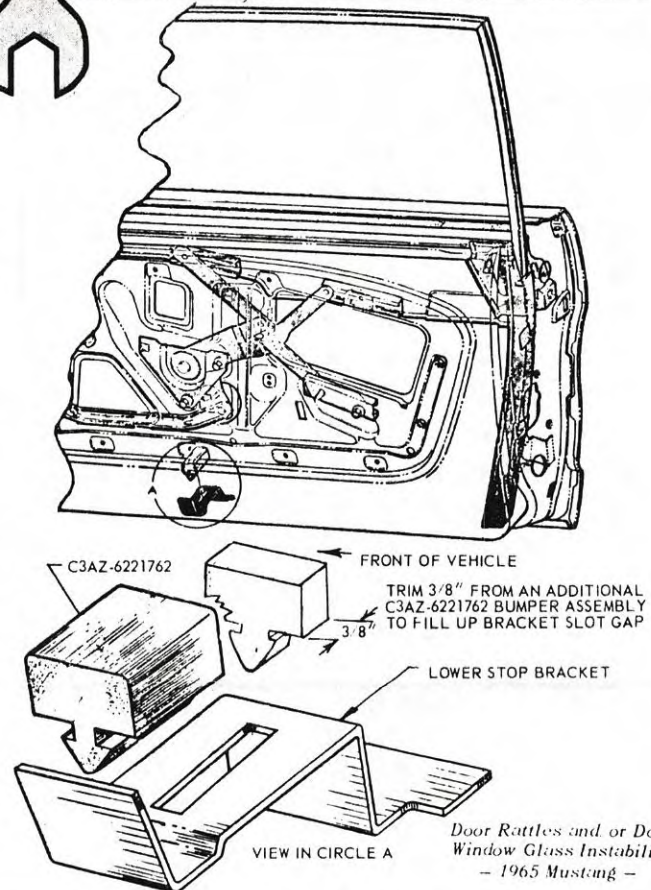

Door Rattles and or Door Window Glass Instability - 1965 Mustang -

## CRACKS IN SEALER AND POOR APPEARANCE OF SEALER IN DRIP RAILS

(1969 - Mustang Without Vinyl Top)

Some early built 1969 Mustang vehicles without the vinyl roof have revealed cracks in the sealer and/or a poor sealer appearance between the quarter roof and roof rail. Occasionally these problems will result from the difficulty encountered during the installation of the rear outside quarter window moldings.

In the event you are confronted with objectionable drip rail sealer appearance and/or cracks in the roof drip rail, a satisfactory repair can be accomplished by the following procedure.

1. Clean area of drip rail of any loose or foreign material.

2. Apply sufficient amount of ESB-M4-G-103-A air dry vinyl sealer to cover the joint of the roof to the drip rail extension. (In the case of hairline cracks, assure that the sealer is worked into the crack.)

3. Smooth out vinyl sealer with wooden dowel or other applicable tool which has been moistened with solvent (naptha).

4. Clean off any excess sealer from adjacent area.

5. Allow the sealer to dry for 15 minutes, then with touch-up brush, apply air dry lacquer or enamel in the appropriate color to the sealer.

NOTE: The M4-G-103-A sealer will quickly skin over permit-

ting the application of the touch-up paint; however, the sealer will not dry through for 48 hours. Therefore, handling precautions must be exercised.

In either case it is not necessary to paint the entire roof panel.

NOTE: The air dry vinyl sealer is manufactured by the Ohio Sealer and Chemical Co., 3060 East River Road, Dayton, Ohio (45439) and is merchandised in five (5) ounce tubes or 1/10 gallon cartridges. Your requirements maybe ordered directly from this source or from local body shop suppliers under trade name "AU-VE-CO" Automotive Body Sealer.

## ACCESSORY DRIVE BELTS

(1965-73 Mustang)

When replacing drive belts, care must be taken to use the correct belt. Investigation has shown incorrect belts have been installed accidentally on a few cars. If there is any doubt that the belt removed is the correct belt, the parts catalog should be consulted. The catalog gives a part number, dimensions, accessory applications, model usage and the engineering number that is stamped on the belt. A cross-check with the parts catalog is especially important when the reason for replacement is lack of adjustment.

# TAKE A BREAK



## MADE FROM WOOD



ARMOIRE  
BOARD  
CHEST  
CUTTING  
FAN  
HEADBOARD  
MOLDING  
ROCKER  
SHOES  
SOFA  
SWING  
TOY

BASKET  
CABINET  
CRADLE  
DRESSER  
FLOOR  
HIGHCHAIR  
PLANTER  
SCULPTURE  
SILL  
STOOL  
TABLE  
TRAY

BENCH  
CHAIR  
CRIB  
END  
FRAME  
LOOM  
RACK  
SEAT  
SLED  
SWAB  
TOOTHPICK  
WINDOW

### Deft Definitions

- FANATIC:** A person who's enthusiastic about something in which you have no interest. —Albert J. Nimeth, *Grow Old Gracefully* (Franciscan Press)
- BIGAMY:** Only crime where two rites make a wrong. —Bob Hope
- FLATTERY:** The art of telling a person exactly what he thinks of himself. —Paul H. Gilbert
- BORE:** A person whose life is an open book ... that you don't want to read. —Joey Adams
- STATISTICS:** Numbers looking for an argument. —*Changing Times*
- PRENUPTIAL AGREEMENT:** An "I do" with an asterisk. —*Current Comedy*

...

Isn't it strange how many people who have no problem giving the Lord credit are reluctant to give him cash?

